



**Technical Service
BULLETIN**

April 17, 2007

Title:

**ACCESSORY DRIVE BELT/
BELT TENSIONER ASSEMBLY NOISE**

Models:

'03 – '07 Corolla & Matrix

**ENGINE
EG021-07**

Introduction Some 1ZZ-FE and 2ZZ-GE engines may exhibit a squealing and/or rattling noise coming from the engine compartment during vehicle operation. The belt tensioner assembly has been improved to correct this condition.

- Applicable Vehicles**
- **2003 – 2007** model year **Corolla** and **Matrix** vehicles produced **BEFORE** the Production Change Effective VINs shown below.

**Production
Change
Information**

MODEL	PLANT	PRODUCTION CHANGE EFFECTIVE VIN
Corolla	NUMMI	1NXB*3#E*7Z841089
	TMMC	2T1B*3#E*7C776998
	TMC	JTDB*3#E*70116547
Matrix	TMMC	2T1K*3#E*7C653444

**Parts
Information**

ENGINE	PREVIOUS PART NUMBER	CURRENT PART NUMBER	PART NAME	QTY
1ZZ-FE	16620-22012	16620-22013	Tensioner Assembly, V-belt	1
2ZZ-GE	16620-22032	16620-22033		1
1ZZ-FE	90080-91139-83	Same	Belt, V	1
2ZZ-GE	90916-A2007	Same		1

**Warranty
Information**

OP CODE	DESCRIPTION	TIME	OFF	T1	T2
EG7018	R & R Accessory Drive Belt & Belt Tensioner	0.6	16620-2201# 16620-2203#	91	99

Applicable Warranty*:

This repair is covered under the Toyota Comprehensive Warranty. This warranty is in effect for 36 months or 36,000 miles, whichever occurs first, from the vehicle's in-service date.

* Warranty application is limited to correction of a problem based upon a customer's specific complaint.



Repair Procedure

1. Verify that the noise is coming from the accessory drive belt/belt tensioner assembly.
2. Inspect the accessory drive belt and belt tensioner assembly.
If there is any roughness to either of the belt tensioner assembly bearings or any sign of damage, scoring, or glazing on the accessory drive belt, replace BOTH the belt tensioner assembly and the accessory drive belt.
3. Remove the drive belt.

1ZZ-FE:

- A. Remove the engine under cover RH.
- B. Remove the drive belt.
 - a. Turn the drive belt tensioner clockwise to relieve tension on the belt, and then remove the belt.
 - b. Carefully return the tensioner to the unloaded position.

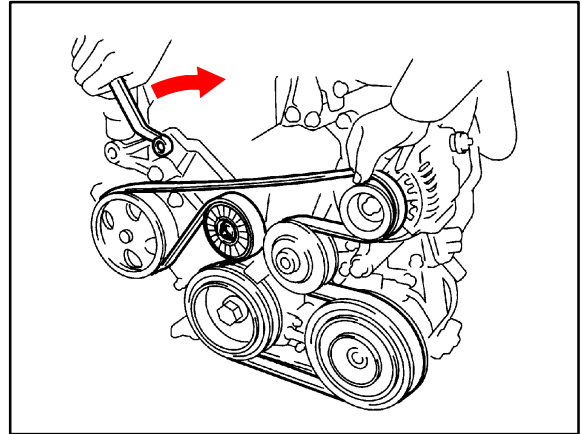
**NOTE:**

- When retracting the tensioner, turn it clockwise **SLOWLY** in 3 seconds or more. Do **NOT** apply force rapidly.
- After the tensioner is retracted all the way, do **NOT** apply more force than is necessary.

2ZZ-GE:

- A. Remove the engine under cover RH.
- B. Remove the wire harness protector.
 - a. Unfasten the 3 clips, then remove the wire harness protector.
 - b. Disconnect the pressure sensor connector.

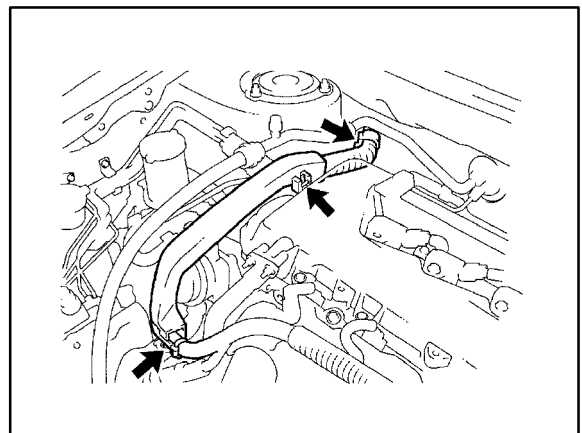

**Repair
Procedure**
(Continued)

- C. Disconnect the suction hose sub-assembly.
- Remove the 2 nuts installing the suction hose sub-assembly.
 - Disconnect the suction hose sub-assembly.

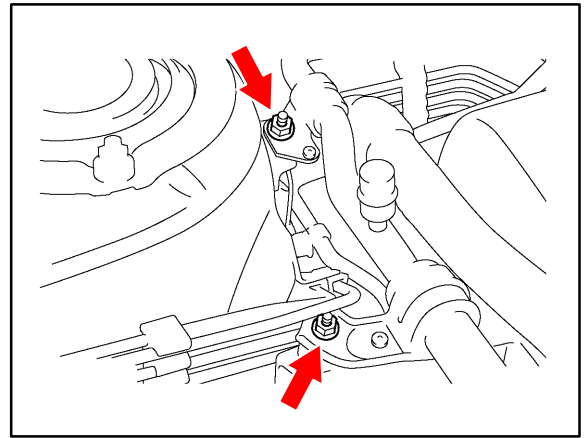

- D. Remove the drive belt.
- Turn the drive belt tensioner clockwise to relieve tension on the belt, and then remove the belt.
 - Carefully return the tensioner to the unloaded position.

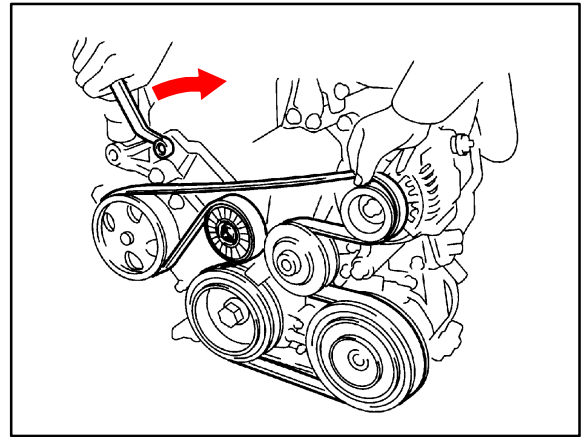

NOTE:

- When retracting the tensioner, turn it clockwise **SLOWLY** in 3 seconds or more. Do **NOT** apply force rapidly.
- After the tensioner is retracted all the way, do **NOT** apply more force than is necessary.

4. Remove and replace the belt tensioner assembly.

1ZZ-FE:

Install a NEW drive belt tensioner assembly with the bolt and nut.

Torque:

Bolt: 69 N•m (704 kgf•cm, 51 ft•lbf)

Nut: 29 N•m (296 kgf•cm, 21 ft•lbf)

2ZZ-GE:

Install a NEW drive belt tensioner assembly with the bolt and nut.

Torque:

Bolt: 100 N•m (1020 kgf•cm, 74 ft•lbf)

Nut: 29 N•m (296 kgf•cm, 21 ft•lbf)

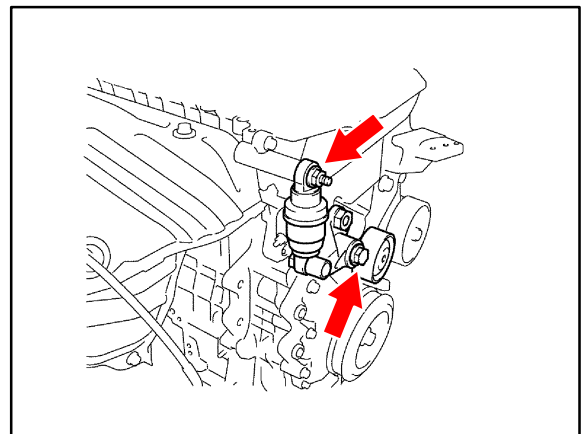

**Repair
Procedure**
(Continued)

5. Slowly move the belt tensioner at LEAST 4 times through its full stroke. (It should take at LEAST 3 seconds to work it through one full stroke.) This will release any air from the tensioner assembly and prime it for proper operation.

6. Install a NEW drive belt.

7. Install the engine under cover.

1ZZ-FE:

Install the engine under cover RH.

2ZZ-GE:

A. Install the suction hose sub-assembly.

Torque: 9.8 N•m (100 kgf•cm, 87 in.•lbf)

B. Install the wire harness protector.

C. Install the engine under cover RH.

Torque: 7.0 N•m (71 kgf•cm, 62 in.•lbf)

8. Confirm the repair.